

CORE

Sliding technology

CORE

linear sliding bearings

30 years of experience in sliding technology



Advantages of CORE bearings:

- Low friction coefficient.
- Bi-directional displacements allowed.
- Maintenance free.
- Chemical inert, no degeneration.
- Long lifetime.
- Compact design
- Easy to install
- No risk of fatigue failure

The support that allows bi-directional displacements.

CORE low friction sliding bearings will support pipelines or mechanical constructions and allow unlimited displacements caused by temperature elongation. Due to the low friction coefficient the material stress is reduced to a minimum.

The CORE bearings are of a compact design and can be easily fit into any construction.

The CORE bearings generally operate under high loads and slow sliding velocity. Under these conditions there is almost no wear and the lifespan of the bearing is most likely to exceed the lifespan of the supported construction.

Key figures:

- Loads up to 7000 kN
- Temperatures up to 600°C
- Maintenance free
- Reliable
- Easy to install
- Standard modules
- Specials up on request

1 | www.hanwel.com



It's all about friction.

Linear sliding supports should take up the load and allow displacements. In order to reduce the material stress of the supported construction the friction in the sliding support should be as low as possible.

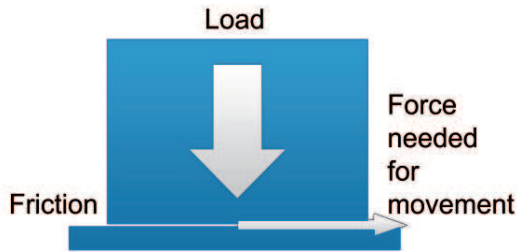

Of all known materials PTFE has the lowest friction coefficient. The CORE bearings have a sliding pad out of modified PTFE or an engineered plastic with a PTFE supplement.

The friction coefficient will be at a minimum when the stress in the PTFE is at a maximum and the counter surface is mirror polished. By using special PTFE compounds the stress in the PTFE can be influenced in a positive way without reducing the maximum allowable load.

Therefore the Core slide bearings have the lowest friction coefficient of all known types of bearings.

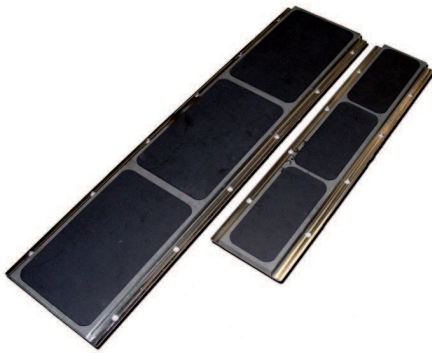

Friction coefficient of different material combinations:

Steel on steel	0,30
PTFE on polished stainless steel – dry	0,06-0,10
PTFE on polished stainless steel – lubricated	0,03-0,06
Under optimal load conditions, with a polished counter plate ($Rz \leq 1 \mu\text{m}$, $Ra \leq 0,2 \mu\text{m}$)	

Table of contents

	Page
Introduction	1
It's all about friction	2
The principle	3
Friction, load and temperature	4
Sliding pads, constructional rules and guidelines	5
Product overview	6
Type WB	7
Type RB	8
Type BB	9
Type BBS	10
Type RBB	11
Type WBH	12
Type WBH-G	13
Type BBH	14
Type BBH-G	15
Type WBC	16
Type WBC-G	17
Type BBC	18
Type BBC-G	19
Type WBI	20
Counter plates	21
Specials	22

Although we supply a large number of standard types and an even larger number of special types all sliding bearings are based on the same principle. Each bearing consist out of a:

Backing plate of the counter plate

Can be welded or bolted to the top construction.
For high temperatures a special, insulated backing plate will be applied.

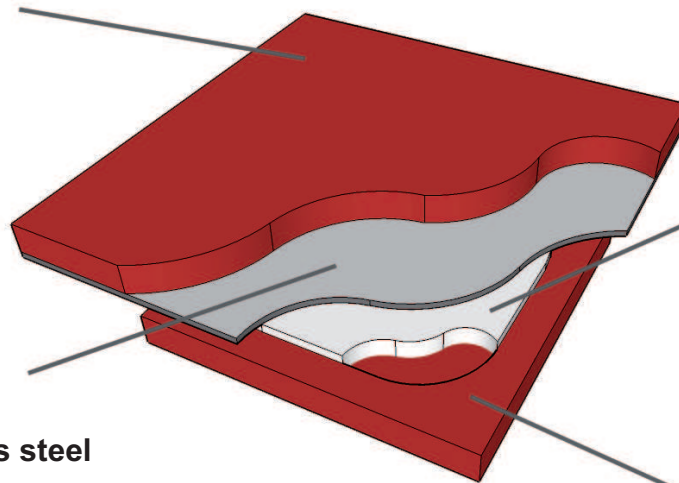

Sliding pad

Low friction pad available in different material compositions

Polished stainless steel counter plate

Thickness 2 mm or 3 mm
Roughness Rz:1 μm , Ra: 0,2 μm)

Base plate

With chamber that contains the sliding pad
Can be welded or bolted to the base construction

Backing plate of the counter plate:

The backing plate supports the stainless steel counter plate.
Standard execution : carbon steel with primer.
Connection : welded or bolted.

Polished stainless steel counter plate:

The stainless steel counter plate is circumferential welded to the backing plate. The polished counter plate must have a roughness of Rz:1 μm , Ra: 0,2 μm to ensure an optimum friction coefficient.

Sliding pad:

The sliding pad is chambered in the base plate. This increases the load capacity and ensures a reliable operation of the bearing. Different types of modified PTFE or engineered plastics with PTFE supplement can be supplied. (See page 5 sliding pads.)

Base plate:

The base plate is equipped with a chamber that contains the sliding pad. There are different types of base plates available.
Standard execution : carbon steel with primer.
Connection : welded or bolted.

Friction

The friction coefficient is depending of many factors, such as the surface finish of the counter plate, the load, the sliding velocity and the temperature. The friction coefficient of the CORE sliding plates is approx. 0,06 to 0,10 in case a polished stainless steel counter plate is applied. This plate should have a roughness of Rz:1 µm, Ra: 0,2 µm (A lower or higher roughness will increase the friction coefficient.) The best friction coefficient can be obtained by using a CORE bearing in combination with a CORE counter plate.

The friction coefficient can even be reduced by using a dimpled PTFE plate and special, life time, lubrication. The friction coefficient then will be approx 0,03 to 0,06.

Load



For our standard program the load range is specified per type and dimension. In general you will need a larger contact area for higher loads. Specials are calculated according to your demands and the design conditions specified

Temperature

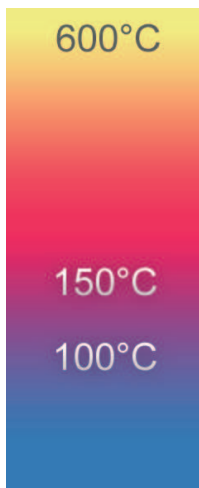

High Temperature sliding pad with insulated counter plate **PTFE-HT** **up to 600°C**

The CORE sliding bearings can be used for high temperature pipe lines and constructions. The maximum allowable temperature at the sliding pad however is 150 °C. In case the supported construction has a higher temperature than 150°C a bearing with an insulated counter plate should be used. The insulated counter plate will reduce the temperature to the maximum allowable 150°C (PTFE-HT). The insulated counter plate will also reduce the heat loss of the supported system.

High Temperature sliding pad **PTFE-HT** **up to 150°C**

Standard sliding pad **PTFE-W** **up to 100°C**

Please note that the maximum allowable temperature at the sliding plate is 150°C

Sliding pads



The bearings can be supplied with different types of sliding pads. The standard types available are:

- PTFE-W** Standard sliding pad for temperatures up to 100°C
Colour: white.
- PTFE-WD** Dimpled sliding pad for temperatures up to 100°C
Reduced friction coefficient due to a lifetime lubrication.
Colour: white
- PTFE-HT** Standard sliding pad for temperatures up to 150°C
Colour: black
- PTFE-HTD** Dimpled sliding pad for temperatures up to 150°C
Reduced friction coefficient due to a lifetime lubrication.
Colour: black

For special applications or conditions there are other types of sliding pads available. The maximum size of a sliding pad is 1200 x 1200 mm

Constructional rules and guidelines

For a good functional and maintenance free operation the following instructions are of major importance.

These instructions should be followed at all times.

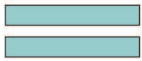

The top and bottom part of your construction should be installed in parallel planes in case you use flat sliding bearings. This to ensure that the load is transferred over the complete contact area.



In case an angular displacement is expected one should use cup shaped bearings.



The top and bottom part of your construction should be rigid enough to avoid bending of the counter plate and housing of the bearing.

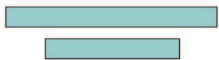

The PTFE pad must be completely covered by the counter plate at all operational conditions. The counter plate must always be on top.

Welding

Fixation of weldable base plates and counter plates should be by tack welding. In case the plates are fully welded the temperature at the PTFE sliding pad should not exceed 250°C If necessary the welding should be done in steps. Protect the sliding pad and stainless steel plate against weld spatter.

Positioning

The standard execution is for horizontal use only. In case the bearings are used upside down or in a vertical position one must ensure that the sliding-pad can not fall out of the base plate. So keep the sliding-pad secured during handling or order an execution with sliding-pads that are secured to the base plate by means of a screw.

Maintenance

The CORE sliding bearings are maintenance free. However it is of importance that the bearings are installed in the right way and that the sliding-pad and stainless steel plate are kept free from dirt.

Flat

Cup shaped

Insulated

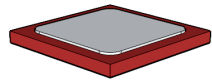

type

WB

Description

Welded Bearing for welding on to the steel construction.
Square or rectangular base plate.
A counter plate must be ordered separately.

page

7



RB

Round welded Bearing for welding on to the steel construction.
Round base plate.
A counter plate must be ordered separately

8

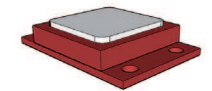

BB

Bolted Bearing for bolting to the steel construction.
Square or rectangular base plate.
A counter plate must be ordered separately

9

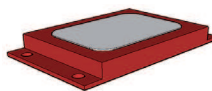

BBS

Bolted Bearing Small side for bolting to the steel construction.
Rectangular base plate. Bolted on the small side
A counter plate must be ordered separately

10



RBB

Round Bolted Bearing for bolting to the steel construction.
Round base plate.
A counter plate must be ordered separately

11

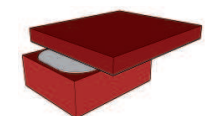

WBH

Welded Bearing High for welding on to the steel construction.
Execution with high base plate.
Delivery including counter plate.

12

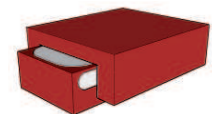

WBH-G

Welded Bearing High-Guided for welding on to the construction.
Execution with high base plate and guide in one direction.
Delivery including counter plate.

13

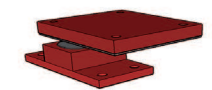

BBH

Bolted Bearing High for bolting to the steel Construction.
Execution with high base plate.
Delivery including counter plate.

14

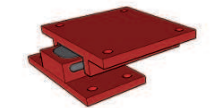

BBH-G

Bolted Bearing High-Guided for bolting to the steel construction.
Execution with high base plate and guide in one direction.
Delivery including counter plate.

15

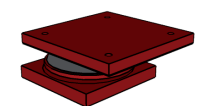

WBC

Welded Bearing Cup shaped for welding on to the construction.
Angular displacement allowed.
Delivery including counter plate

16

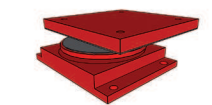

WBC-G

Welded Bearing Cup shaped-Guided
Execution as above however with guide in one direction.

17

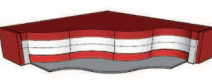

BBC

Bolted Bearing Cup shaped for bolting to the steel construction.
Angular displacement allowed.
Delivery including counter plate

18

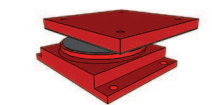

BBC-G

Bolted Bearing Cup shaped-Guided
Execution as above however with guide in one direction.

19

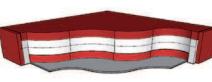

WBI

Welded Bearing Insulated for welding on to the construction.
Execution with insulated counter plate for high temperature applications
Delivery including counter plate.

20

Type WB

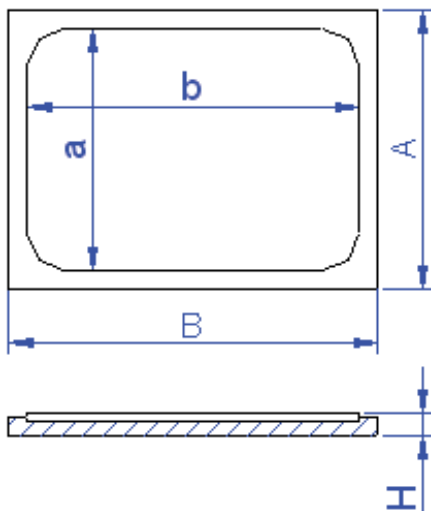

Materials	carbon steel base plate with primer (1 layer primer) PTFE pad, thickness: 5 mm
Category	Flat
Fixation	By welding

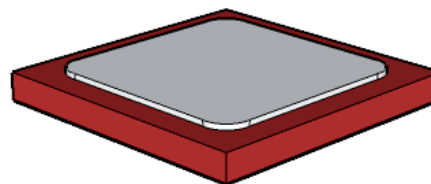

Type WB	Load	Dimesions				
Dimensions in mm	kN	H	A	B	a	b
WB 50 x 50 - 10	13	10	50	50	Ø 40	
WB 50 x 100 - 10	23	10	50	100	30	80
WB 50 x 150 - 10	38	10	50	150	30	130
WB 50 x 200 - 10	53	10	50	200	30	180
WB 100 x 100 - 12	60	12	100	100	80	80
WB 100 x 150 - 12	100	12	100	150	80	130
WB 100 x 200 - 12	140	12	100	200	80	180
WB 100 x 250- 12	180	12	100	250	80	230
WB 100 x 300- 12	220	12	100	300	80	280
WB 150 x 150 - 12	165	12	150	150	130	130
WB 150 x 200 - 12	230	12	150	200	130	130
WB 150 x 250 - 12	295	12	150	250	130	230
WB 150 x 300 - 12	360	12	150	300	130	280
WB 200 x 200 - 12	320	12	200	200	180	180
WB 200 x 250 - 12	410	12	200	250	180	230
WB 200 x 300 - 12	500	12	200	300	180	280

Ordering information: specify the type and the required sliding pad

For example: WB 200 x 300 – 12 – HT
This is a base plate of 200 x 300 mm. Total height: 12 mm Sliding pad type: HT, for temperatures up to 150°C

To ensure proper and reliable operating a stainless steel counter plate (CP) must be applied.
See the applicable data sheets.

Available sliding pads:

type	temperature	colour	specification
pad W	max. 100°C	white	
pad WD	max. 100°C	white	dimpled pad
pad HT	max. 150°C	black	
pad HTD	max. 150°C	black	dimpled pad

Special sizes upon request

Please follow the rules and guidelines concerning design

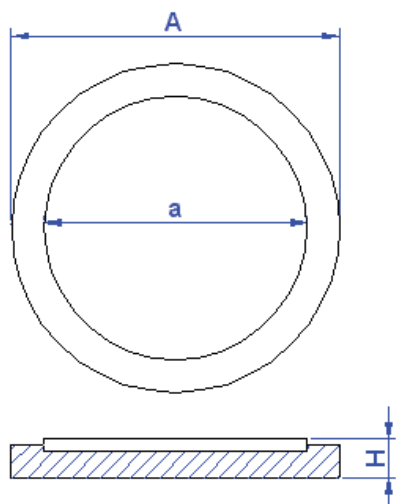

Materials	carbon steel base plate with primer (1 layer primer) PTFE pad, thickness: 5 mm
Category	Flat
Fixation	By welding



Type RB	Load	Dimensions		
Dimensions in mm	kN	H	A	a
RB 50 - 10	13	10	Ø 50	Ø 40
RB 80 - 12	30	12	Ø 80	Ø 60
RB 100 - 12	50	12	Ø 100	Ø 80
RB 120 - 12	80	12	Ø 120	Ø 100
RB 150 - 12	130	12	Ø 150	Ø 130
RB 180 - 12	200	12	Ø 180	Ø 160
RB 200 - 12	250	12	Ø 200	Ø 180
RB 250 - 12	410	12	Ø 250	Ø 230
RB 300 - 12	610	12	Ø 300	Ø 280
Ordering information: specify the type and the required sliding pad				
For example: RB 50 x 10 – W				
This is a base plate of Ø 50 mm. Total height: 10 mm Sliding pad type: W, for temperatures up to 100°C				

To ensure proper and reliable operating a stainless steel counter plate (CP) must be applied. See the applicable data sheets.

Available sliding pads:

type	temperature	colour	specification
pad W	max. 100°C	white	
pad WD	max. 100°C	white	dimpled pad
pad HT	max. 150°C	black	
pad HTD	max. 150°C	black	dimpled pad

Special sizes upon request
Please follow the rules and guidelines concerning design

Type BB

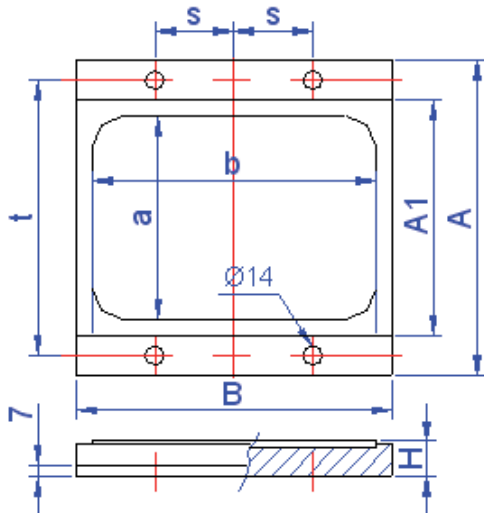

Materials	carbon steel base plate with primer (1 layer primer) PTFE pad, thickness: 5 mm
Category	Flat
Fixation	By bolting

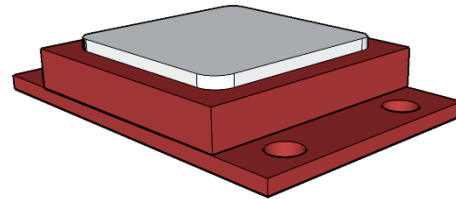

Type BB	Load	Dimensions						holes		
		H	A	A1	B	a	b	s	t	qty
BB 50 x 50 - 22	13	22	100	50	50	Ø 40		0	75	2
BB 50 x 100 - 22	23	22	100	50	100	30	80	30	75	4
BB 50 x 150 - 22	38	22	100	50	150	30	130	50	75	4
BB 50 x 200 - 22	53	22	100	50	200	30	180	75	75	4
BB 100 x 100 - 22	60	22	150	100	100	80	80	30	125	4
BB 100 x 150 - 22	100	22	150	100	150	80	130	50	125	4
BB 100 x 200 - 22	140	22	150	100	200	80	180	75	125	4
BB 100 x 250 - 22	180	22	150	100	250	80	230	200	125	4
BB 100 x 300 - 22	220	22	150	100	300	80	280	125	125	6
BB 150 x 150 - 22	165	22	200	150	150	130	130	50	175	4
BB 150 x 200 - 22	230	22	200	150	200	130	180	75	175	4
BB 150 x 250 - 22	295	22	200	150	250	130	230	200	175	4
BB 150 x 300 - 22	360	22	200	150	300	130	280	125	175	6
BB 200 x 200 - 22	320	22	250	200	200	180	180	75	225	4
BB 200 x 250 - 22	410	22	250	200	250	180	230	200	225	4
BB 200 x 300 - 22	500	22	250	200	300	180	280	125	225	6

Ordering information: specify the type and the required sliding pad

For example: BB 200 x 300 – 22 – HT

This is a base plate of 200 x 300 mm. The total height: 22 mm Sliding pad type: HT, for temperatures up to 150°C

To ensure proper and reliable operating a stainless steel counter plate (CP) must be applied.
See the applicable data sheets.

Available sliding pads:

type	temperature	colour	specification
pad W	max. 100°C	white	
pad WD	max. 100°C	white	dimpled pad
pad HT	max. 150°C	black	
pad HTD	max. 150°C	black	dimpled pad

Special sizes upon request

Please follow the rules and guidelines concerning design

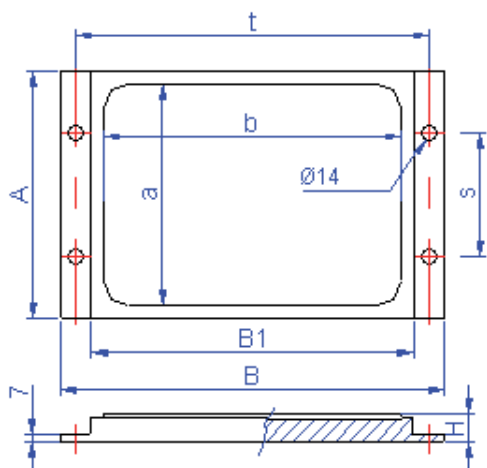

Materials	carbon steel base plate with primer (1 layer primer) PTFE pad, thickness: 5 mm
Category	Flat
Fixation	By bolting

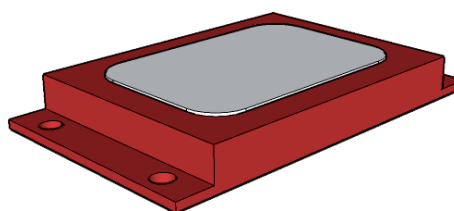

Type BBS	Load	Dimensions						holes		
Dimensions in mm	kN	H	A	B	B1	a	b	s	t	qty
BBS 50 x 100 – 22	23	22	50	150	100	30	80	0	125	2
BBS 50 x 150 – 22	38	22	50	200	150	30	130	0	175	2
BBS 50 x 200 – 22	53	22	50	250	200	30	180	0	225	2
BBS 100 x 150 – 22	100	22	100	200	150	80	130	60	175	4
BBS 100 x 200 – 22	140	22	100	250	200	80	180	60	225	4
BBS 100 x 250 – 22	180	22	100	300	250	80	230	60	275	4
BBS 100 x 300 – 22	220	22	100	350	300	80	280	60	325	4
BBS 150 x 200 – 22	230	22	150	250	200	130	180	100	225	4
BBS 150 x 250 – 22	295	22	150	300	250	130	230	100	275	4
BBS 150 x 300 – 22	360	22	150	350	300	130	230	100	325	4
BBS 200 x 250 – 22	410	22	200	300	250	180	230	150	275	4
BBS 200 x 300 – 22	500	22	200	350	300	180	280	150	325	4

Ordering information: specify the type and the required sliding pad

For example: BBS 200 x 300 – 22 – HT

This is a base plate of 200 x 350 / 300 mm. Total height: 22 mm Sliding pad type: HT, for temperatures up to 150°C

To ensure proper and reliable operating a stainless steel counter plate (CP) must be applied.
See the applicable data sheets.

Available sliding pads:

type	temperature	colour	Specification
pad W	max. 100°C	white	
pad WD	max. 100°C	white	dimpled pad
pad HT	max. 150°C	black	
pad HTD	max. 150°C	black	dimpled pad

Special sizes upon request
Please follow the rules and guidelines concerning design

Type RBB

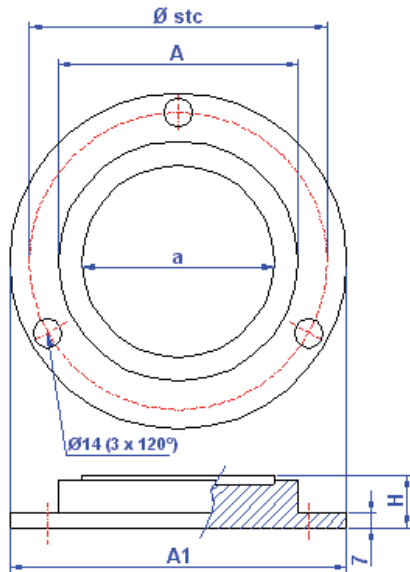

Materials	carbon steel base plate with primer (1 layer primer) PTFE pad, thickness: 5 mm
Category	Flat
Fixation	By bolting



Type RBB	Load	Dimensions					
Dimensions in mm	kN	H	A	a	A1	stc	hole
RBB 50 - 22	13	22	Ø 50	Ø 40	Ø 90	Ø 70	Ø14
RBB 80 - 22	30	22	Ø 80	Ø 60	Ø 120	Ø 100	Ø14
RBB 100 - 22	50	22	Ø 100	Ø 80	Ø 150	Ø 125	Ø14
RBB 120 - 22	80	22	Ø 120	Ø 100	Ø 170	Ø 145	Ø14
RBB 150 - 22	130	22	Ø 150	Ø 130	Ø 200	Ø 175	Ø14
RBB 200 - 22	250	22	Ø 200	Ø 180	Ø 260	Ø 230	Ø14
RBB 250 - 22	410	22	Ø 250	Ø 230	Ø 310	Ø 280	Ø14
RBB 300 - 22	610	22	Ø 300	Ø 280	Ø 360	Ø 330	Ø14
Ordering information: specify the type and the required sliding pad							
For example: RBB 50 x 22 - W							
This is a base plate of Ø 50 / 90 mm. Total height: 22 mm Sliding pad type: W, for temperatures up to 100°C							

To ensure proper and reliable operating a stainless steel counter plate (CP) must be applied.
See the applicable data sheets.

Available sliding pads:

type	temperature	colour	specification
pad W	max. 100°C	white	
pad WD	max. 100°C	white	dimpled pad
pad HT	max. 150°C	black	
pad HTD	max. 150°C	black	dimpled pad

Special sizes upon request

Please follow the rules and guidelines concerning design

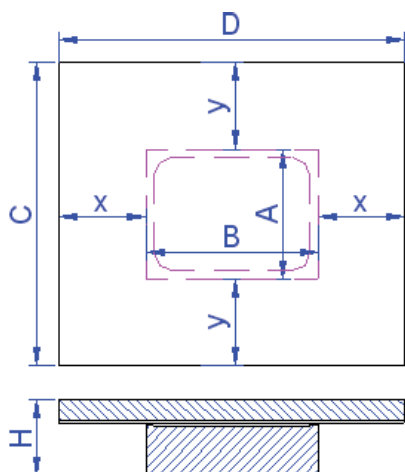

Materials	carbon steel base and counter plate with primer (1 layer primer) PTFE pad, thickness: 5 mm
Category	Flat
Fixation	By welding

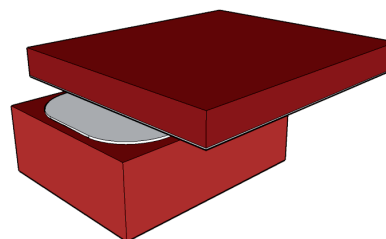

The displacement x is responsible for the counter plate size D
The displacement y is responsible for the counter plate size C

Type WBH	Load kN	Dimensions									
		H	A	B	x,y : ±20		x,y : ±40		x,y : ±80		
					C	D	C	D	C	D	
WBH 100	100	55	100	90	140	130	180	170	260	250	
WBH 250	250	70	100	190	140	230	180	270	260	350	
WBH 500	500	90	150	190	190	230	230	270	310	350	
WBH 750	750	95	150	240	190	280	230	320	310	400	
WBH 1000	1000	95	200	240	240	280	280	320	360	400	
WBH 1250	1250	125	200	290	240	330	280	370	360	450	
WBH 1500	1500	125	250	270	290	310	330	350	410	430	
WBH 2000	2000	135	300	300	340	340	380	380	460	460	

Ordering information: specify the type, the x and y displacement and the required sliding pad

For example: WBH 1000 W displacement x and y: ± 20 mm
This is a complete bearing including counter plate suitable for a load of 1000 kN The dimension of the base plate is 200 x 240 mm, The dimension of the counter plate is 240 x 280 mm, The height is 95 mm
The sliding pad is type W, suitable for temperatures up to 100°C

Available sliding pads:			
type	temperature	colour	specification
pad W	max. 100°C	white	
pad WD	max. 100°C	white	dimpled pad
pad HT	max. 150°C	black	
pad HTD	max. 150°C	black	dimpled pad

Special sizes upon request
Please follow the rules and guidelines concerning design

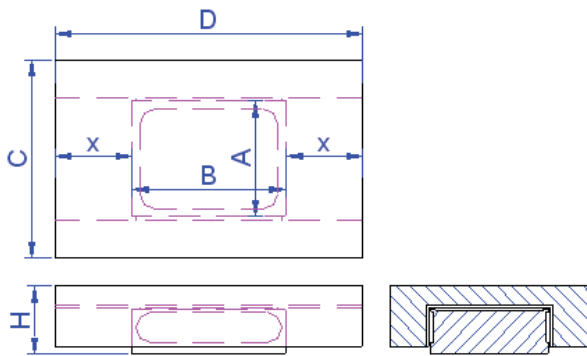

Materials	carbon steel base and counter plate with primer (1 layer primer) PTFE pad, thickness: 5 mm
Category	Flat, guided
Fixation	By welding

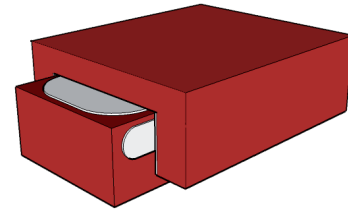

The displacement x is responsible for the counter plate size D
 L_y is the allowable load on the guide.

Type WBH-G	Load kN	L_y kN	Dimensions						
			H	A	B	C	$x: \pm 20$ D	$x: \pm 40$ D	$x: \pm 80$ D
WBH-G 100	100	30	55	100	90	170	130	170	250
WBH-G 250	250	70	70	100	190	170	230	270	350
WBH-G 500	500	120	90	150	190	240	230	270	350
WBH-G 750	750	190	95	150	240	240	280	320	400
WBH-G 1000	1000	200	95	200	240	290	280	320	400
WBH-G 1250	1250	280	125	200	290	290	330	370	450
WBH-G 1500	1500	280	125	250	270	360	310	350	430
WBH-G 2000	2000	380	135	300	300	430	340	380	460

Ordering information: specify the type, the x and y displacement and the required sliding pad

For example: WBH-G 1000 W displacement $x \pm 20$ mm
 This is a complete bearing including counter plate suitable for a load of 1000 kN The dimension of the base plate is 200 x 240 mm, The dimension of the counter plate is 290 x 280 mm, The height is 95 mm
 The sliding pad is type W, suitable for temperatures up to 100°C

Available sliding pads:

type	temperature	colour	specification
pad W	max. 100°C	white	
pad WD	max. 100°C	white	dimpled pad
pad HT	max. 150°C	black	
pad HTD	max. 150°C	black	dimpled pad

Special sizes upon request
 Please follow the rules and guidelines concerning design

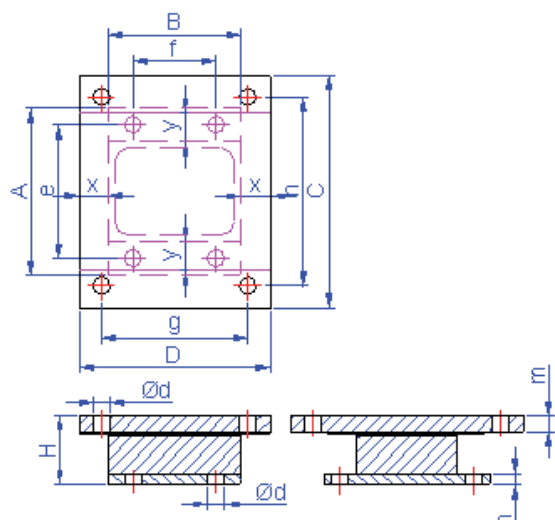

Materials	carbon steel base and counter plate with primer (1 layer primer) PTFE pad, thickness: 5 mm
Category	Flat
Fixation	By bolting

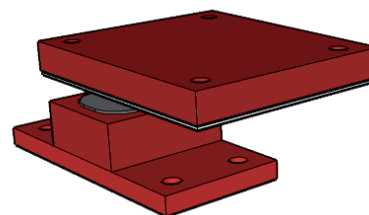

The displacement x is responsible for the counter plate size D
The displacement y is responsible for the counter plate size C

Type BBH	Load kN	Dimensions base plate							Dimensions counter plate								
		H	A	B	e	f	Ød	n	x: ±20				x: ±40				m
									C	D	h	g	C	D	h	g	
BBH 100	100	70	210	100	170	60	14	15	190	140	150	100	230	180	190	140	15
BBH 250	250	85	250	150	200	100	18	15	220	190	170	150	260	230	210	180	20
BBH 500	500	110	310	180	260	130	18	20	270	220	220	180	310	260	260	220	25
BBH 750	750	115	340	250	280	180	22	20	290	290	230	230	330	330	270	270	30
BBH 1000	1000	115	390	250	330	180	22	20	340	290	280	230	380	330	320	270	30
BBH 1250	1250	150	450	250	380	180	26	25	380	290	310	210	420	330	350	240	40
BBH 1500	1500	150	470	250	400	180	26	25	400	290	330	210	440	330	370	240	40
BBH 2000	2000	165	570	300	480	200	32	30	530	340	440	250	570	380	480	290	50

Ordering information: specify the type, the x and y displacement and the required sliding pad

For example: BBH 1000 W displacement x ± 20 mm

This is a complete bearing including counter plate suitable for a load of 1000 kN The dimension of the base plate is 390 x 250 mm, The dimension of the counter plate is 340 x 290 mm, The height is 115 mm

The sliding pad is type W, suitable for temperatures up to 100°C

Available sliding pads:

Type	temperature	colour	specification
Pad W	max. 100°C	white	
Pad WD	max. 100°C	white	dimpled pad
Pad HT	max. 150°C	black	
Pad HTD	max. 150°C	black	dimpled pad

Special sizes upon request

Please follow the rules and guidelines concerning design

Type BHH-G

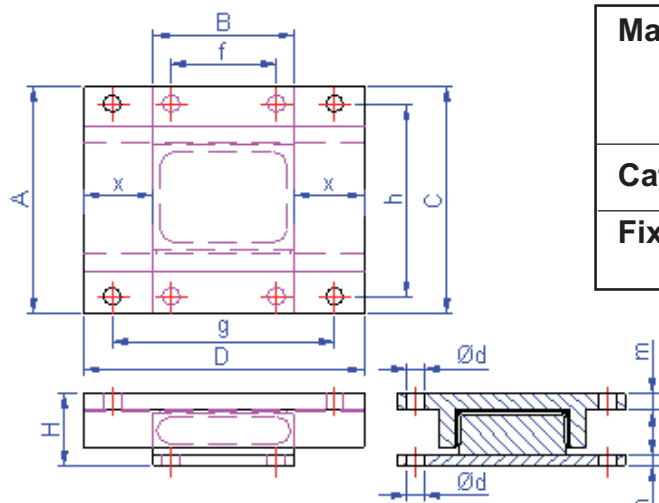

Materials	carbon steel base and counter plate with primer (1 layer primer) PTFE pad, thickness: 5 mm
Category	Flat, guided
Fixation	By bolting

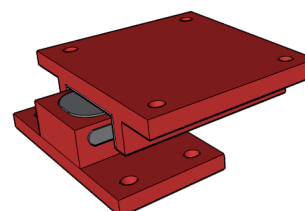

The displacement x is responsible for the counter plate size D
 L_y is the allowable load on the guide.

Type BBH-G	Load	L_y	Dimensions base plate								Dimensions counter plate						
			H	A	B	h	f	$\varnothing d$	n	C	x: ± 20			x: ± 40			m
											D	h	g	D	h	g	
BBH-G 100	100	30	70	210	100	170	60	14	15	210	140	170	100	180	170	140	15
BBH-G 250	250	75	85	250	150	200	100	18	15	250	190	200	150	230	200	180	20
BBH-G 500	500	125	110	310	180	260	130	18	20	310	220	260	180	260	260	220	25
BBH-G 750	750	200	115	340	250	280	180	22	20	340	290	280	230	330	280	270	30
BBH-G 1000	1000	200	115	390	250	330	180	22	20	390	290	330	230	330	330	270	30
BBH-G 1250	1250	300	150	450	250	380	180	26	25	450	290	380	210	330	380	240	40
BBH-G 1500	1500	300	150	470	250	400	180	26	25	470	290	400	210	330	400	240	40
BBH-G 2000	2000	400	165	570	300	480	200	32	30	570	340	480	250	380	480	290	50

Ordering information: specify the type, the x and y displacement and the required sliding pad

For example: BBH-G 1000 W displacement $x \pm 20$ mm

This is a complete bearing including counter plate suitable for a load of 1000 kN The dimension of the base plate is 390 x 250 mm, The dimension of the counter plate is 390 x 290 mm, The height is 115 mm

The sliding pad is type W, suitable for temperatures up to 100°C

Available sliding pads:

Type	temperature	colour	specification
Pad W	max. 100°C	white	
Pad WD	max. 100°C	white	dimpled pad
Pad HT	max. 150°C	black	
Pad HTD	max. 150°C	black	dimpled pad

Special sizes upon request

Please follow the rules and guidelines concerning design

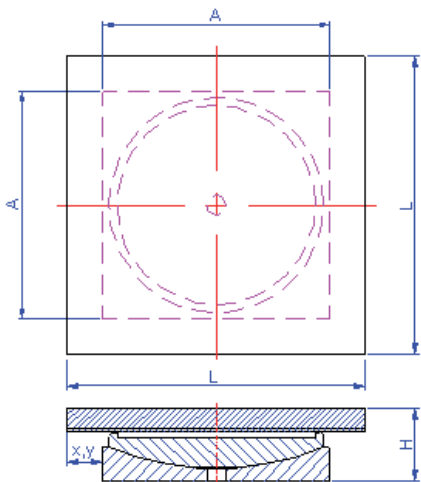

Materials	carbon steel base and counter plate with primer (1 layer primer) PTFE pad, thickness: 5 mm
Category	Cup shaped
Fixation	By welding

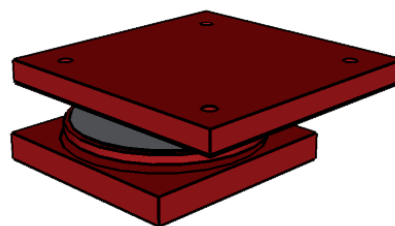

The displacement x,y is responsible for the counter plate size L

Type WBC	Load kN	Dimensions base plate		Dimensions counter plate		
		H	A	x,y:±20	x,y: ±40	x,y: ±80
				L	L	L
WBC 100	100	45	90	120	160	240
WBC 250	250	50	130	160	200	280
WBC 500	500	57	170	200	240	320
WBC 750	750	65	200	230	270	350
WBC 1000	1000	70	230	260	300	380
WBC 1500	1500	75	280	310	350	430
WBC 2000	2000	87	320	350	390	470
WBC 2500	2500	103	360	390	430	510

Ordering information: specify the type, the x and y displacement and the required sliding pad

For example: WBC 1000 HT displacement $x \pm 20$ mm

This is a complete bearing including counter plate suitable for a load of 1000 kN The dimension of the base plate is 230 x 230 mm, The dimension of the counter plate is 260 x 260 mm, The height is 70 mm

The sliding pad is type HT, suitable for temperatures up to 150°C

Available sliding pads:

Type	temperature	colour	specification
Pad W	max. 100°C	white	
Pad WD	max. 100°C	white	dimpled pad
Pad HT	max. 150°C	black	
Pad HTD	max. 150°C	black	dimpled pad

Special sizes upon request

Please follow the rules and guidelines concerning design

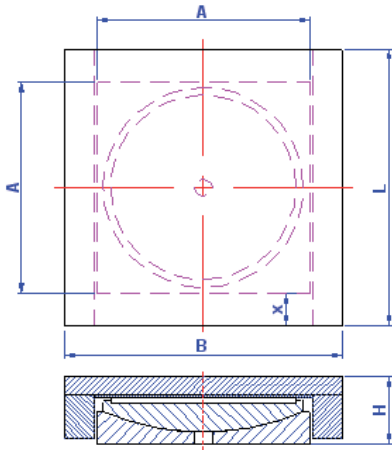

Materials	carbon steel base and counter plate with primer (1 layer primer) PTFE pad, thickness: 5 mm
Category	Cup shaped, guided
Fixation	By welding

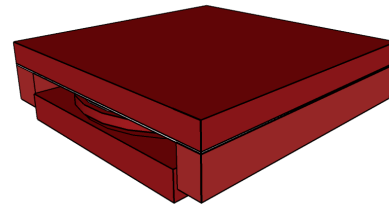

The displacement x is responsible for the counter plate size L

Type WBC-G	Load kN	Ly kN	Dimensions base plate		Dimensions counter plate			
			H	A	B	x,y:±20 L	x,y: ±40 L	x,y: ±80 L
WBC-G 100	100	18	45	90	140	120	160	240
WBC-G 250	250	48	50	130	190	160	200	280
WBC-G 500	500	95	57	170	250	200	240	320
WBC-G 750	750	145	65	200	290	230	270	350
WBC-G 1000	1000	195	70	230	320	260	300	380
WBC-G 1500	1500	295	75	280	400	310	350	430
WBC-G 2000	2000	395	87	320	460	350	390	470
WBC-G 2500	2500	495	103	360	510	390	430	510

Ordering information: specify the type, the x displacement and the required sliding pad

For example: WBC-G 1000 HT displacement $x \pm 20$ mm
 This is a complete bearing including counter plate suitable for a load of 1000 kN The dimension of the base plate is 230 x 230 mm, The dimension of the counter plate is 320 x 260 mm, The height is 70 mm
 The sliding pad is type HT, suitable for temperatures up to 150°C

Available sliding pads:

Type	temperature	colour	specification
Pad W	max. 100°C	white	
Pad WD	max. 100°C	white	dimpled pad
Pad HT	max. 150°C	black	
Pad HTD	max. 150°C	black	dimpled pad

Special sizes upon request

Please follow the rules and guidelines concerning design

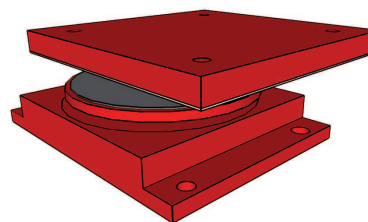
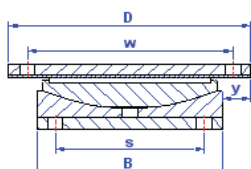
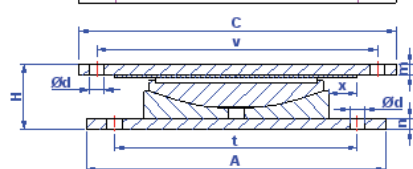
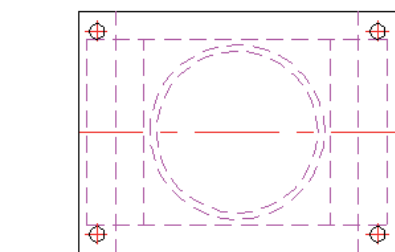

Materials	carbon steel base plate with primer (1 layer primer) PTFE pad, thickness: 5 mm
Category	Cup shaped
Fixation	By bolting

The displacement x is responsible for the counter plate size C
The displacement y is responsible for the counter plate size D

Type BBC	Load kN	Dimensions base plate							Dimensions counter plate								
		H	n	A	B	t	s	Ød	m	x,y:±20				x,y: ±80			
										C	D	v	w	C	D	v	w
BBC 100	100	55	10	200	100	160	60	14	10	190	120	150	80	310	240	270	200
BBC 250	250	65	10	250	140	210	100	14	15	230	160	190	120	350	280	310	240
BBC 500	500	77	15	330	180	280	120	18	20	290	200	240	150	410	320	360	270
BBC 750	750	85	15	370	210	320	150	18	20	320	230	270	180	440	350	390	300
BBC 1000	1000	95	25	420	240	360	170	22	25	360	260	300	190	480	380	420	310
BBC 1500	1500	100	25	520	290	440	200	26	25	430	310	360	230	550	430	480	350
BBC 2000	2000	117	30	620	330	520	230	32	30	500	350	410	250	620	470	530	370
BBC 2500	2500	133	30	670	370	570	270	32	40	540	390	450	290	660	510	570	410

Ordering information: specify the type, the x and y displacement and the required sliding pad

For example: BBC 1000 HT displacement x ± 20 mm

This is a complete bearing including counter plate suitable for a load of 1000 kN The dimension of the base plate is 420 x 240 mm, The dimension of the counter plate is 360 x 260 mm, The height is 95 mm

The sliding pad is type HT, suitable for temperatures up to 150°C

Available sliding pads:

Type	temperature	colour	specification
Pad W	max. 100°C	white	
Pad WD	max. 100°C	white	dimpled pad
Pad HT	max. 150°C	black	
Pad HTD	max. 150°C	black	dimpled pad

Special sizes upon request

Please follow the rules and guidelines concerning design

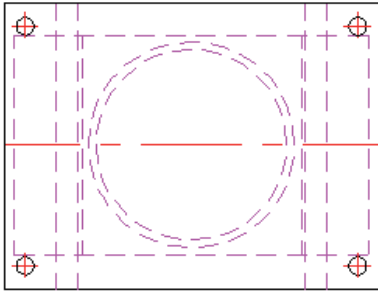

Materials	carbon steel base and counter plate with primer (1 layer primer) PTFE pad, thickness: 5 mm
Category	Cup shaped, guided
Fixation	By bolting

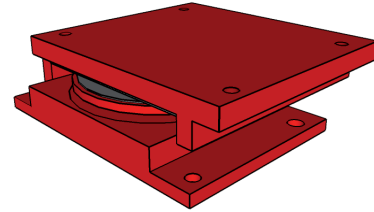
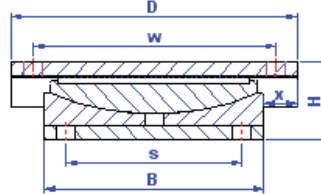
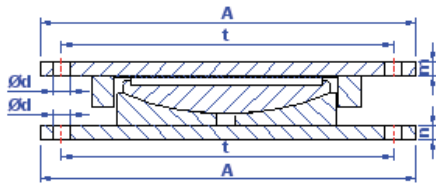

The displacement x is responsible for the counter plate size D

Type BBC-G	Load kN	Ly kN	Dimensions base plate						Dimensions counter plate					
			H	A	B	t	s	Ød	x,y:±20		x,y: ±40		x,y: ±80	
									D	w	D	w	D	w
BBC-G 100	100	18	55	200	100	160	60	14	120	80	160	120	240	200
BBC-G 250	250	48	65	250	140	210	100	14	160	120	200	160	280	240
BBC-G 500	500	95	77	330	180	280	120	18	200	150	240	190	320	270
BBC-G 750	750	145	85	370	210	320	150	18	230	180	270	220	350	300
BBC-G 1000	1000	195	95	420	240	360	170	22	260	190	300	230	380	310
BBC-G 1500	1500	295	100	520	290	440	200	26	310	230	350	270	430	350
BBC-G 2000	2000	395	117	620	330	520	230	32	350	250	390	290	470	370
BBC-G 2500	2500	495	133	670	370	570	270	32	390	290	430	330	510	410

Ordering information: specify the type, the x displacement and the required sliding pad

For example: BBC-G 1000 HT displacement $x \pm 20$ mm

This is a complete bearing including counter plate suitable for a load of 1000 kN The dimension of the base plate is 420 x 240 mm, The dimension of the counter plate is 420 x 260 mm, The height is 95 mm

The sliding pad is type HT, suitable for temperatures up to 150°C

Available sliding pads:

Type	temperature	colour	specification
Pad W	max. 100°C	white	
Pad WD	max. 100°C	white	dimpled pad
Pad HT	max. 150°C	black	
Pad HTD	max. 150°C	black	dimpled pad

Special sizes upon request

Please follow the rules and guidelines concerning design

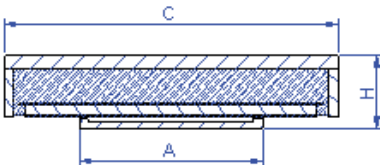
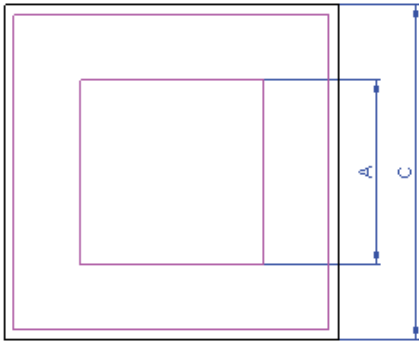

Materials	carbon steel base and counter plate with primer (1 layer primer) PTFE pad, thickness: 5 mm
Category	Flat, Insulated
Fixation	By welding

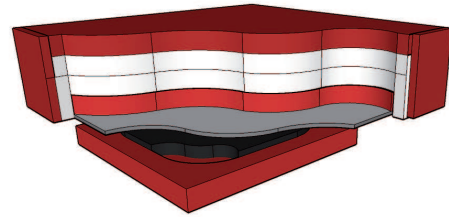

The displacement x,y is responsible for the counter plate size C

Type WBI	Load kN	Dimensions base plate			Dimensions counter plate	
		H 300°C	H 600°C	A	x,y:±25	x,y: ±50
					C	C
WBI 100	100	82	102	100	240	290
WBI 250	250	82	102	150	290	340
WBI 500	500	82	102	200	340	390
WBI 750	750	87	107	225	375	425
WBI 1000	1000	87	107	250	400	450

Ordering information: specify the type, the x and y displacement and the required sliding pad

For example: WBI 1000 HT displacement $x \pm 25$ mm, temperature 300°C
 This is a complete bearing including counter plate suitable for a load of 1000 kN The dimension of the base plate is 250 x 250 mm, The dimension of the counter plate is 400 x 400 mm, The height is 87 mm
 The sliding pad is type HT

Available sliding pads:

Type	temperature	colour	specification
Pad HT	max. 150°C	black	
Pad HTD	max. 150°C	black	dimpled pad

Special sizes upon request
 Please follow the rules and guidelines concerning design

Counter plates must be applied in order to obtain a good and safe operation of the slide bearings. The roughness of the counter plate should be $Rz < 1 \mu\text{m}$, $Ra < 0,2 \mu\text{m}$. The counter plate must be connected to the supported construction and should always cover the slide bearing.

Available types of counter plates;

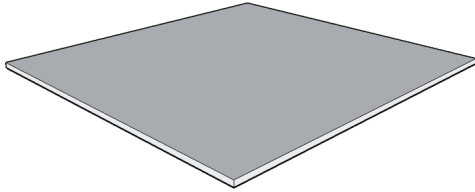

Stainless steel sheet material with the required roughness.

- 2 mm thick stainless steel AISI 316L (EN 1.4404)
- 3 mm thick stainless steel AISI 304 (EN 1.4301)

The sheet material can be delivered in the required sizes. The sheets must be welded to the supported construction. Various applications are possible.

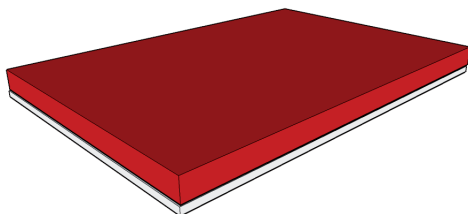
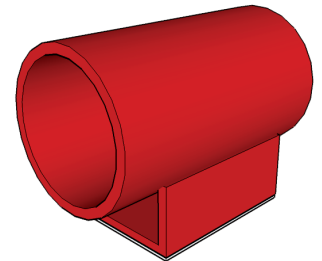
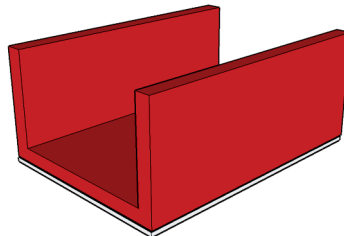
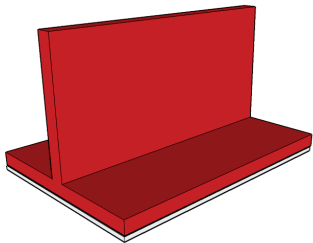

Standard counter plate

Carbon steel counter plate welded on a stainless steel sheet.

The counter plate can be delivered in the required sizes. Various thicknesses available. (based on the thickness of the carbon steel backing plate)

Optional provided with tapped holes.

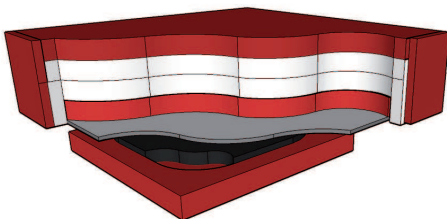

Insulated counter plate

Insulated counter plate that can be used in connection with the sliding pads, type HT and HTD.

Thickness depending of the temperature. (max 600°C)

Special sizes upon request

Please follow the rules and guidelines concerning design

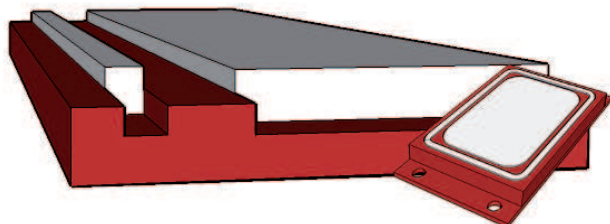

Sliding bearing with dust or dirt scraper

Larger base plate with a dirt scraper on the outside of the sliding pad. Collection of dirt or dust between the sliding pad and the counter plate will be minimized



Sliding bearings for displacement of heavy constructions.

Modular system of light weight base plates out of engineered plastic with round Cup shaped PTFE pads that can be easily replaced.

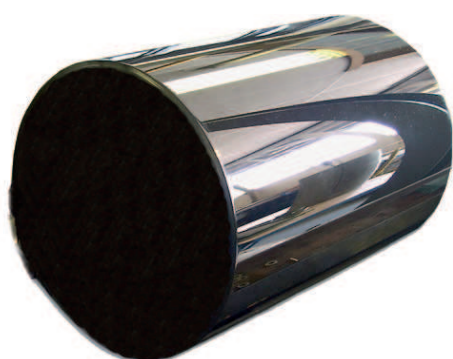

High-core coated steel counter plate

In case it is not possible to use a stainless steel counter plate we can coat the steel counterpart with a high-core ceramic coating. This coating can be applied up to 600°C and has a surface hardness of approx. 2300 HV

Special sizes upon request

Please follow the rules and guidelines concerning design.

HANWEL B.V.

Jan Tinbergenstraat 209
NL-7559 SP Hengelo

phone: +31 (0)74 - 2650000
fax. : +31 (0)74 - 2650001

email: verkoop@hanwel.com
www.hanwel.com

AUG2008